

Additional Accessories

Joint  
To attach electrical box or connect movable profiles.  
Material: zinc plated steel

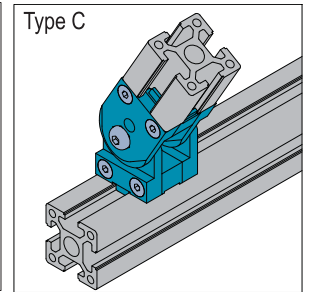

Joint-Type A

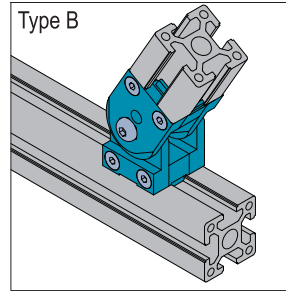
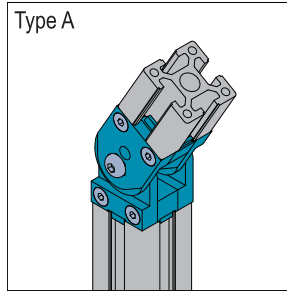
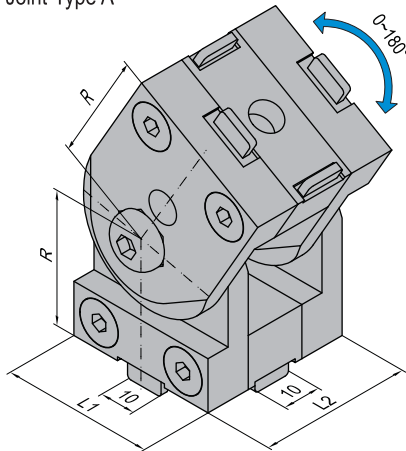



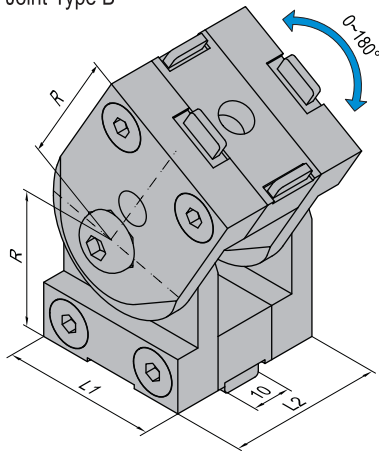

Joint-Type B

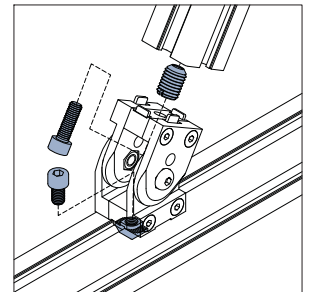
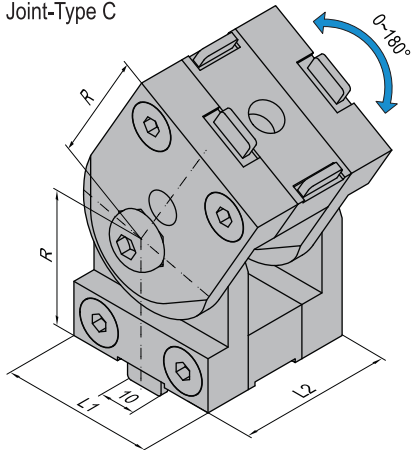

Joint-Type C



FD	Fastening Set	FX	Fastening Set
	M8x16 Bolt zinc plated		M8x20 Bolt zinc plated
	M8 T Nut nickel plated		M14-M8 Hole Reducer Bolt nickel plated

Description	L1(mm)	L2(mm)	R(mm)	Fastening Set	Mass (g)	Part No.
Joint-Type A-4040	40	40	35	2xFX	560	8.31.4040A
Joint-Type A-4060	40	60	35	2xFX	680	8.31.4060A
Joint-Type A-4545	45	45	37.5	2xFX	650	8.31.4545A
Joint-Type A-4560	45	60	37.5	2xFX	800	8.31.4560A
Joint-Type B-4040	40	40	35	1xFD+1xFX	575	8.31.4040B
Joint-Type B-4060	40	60	35	1xFD+1xFX	695	8.31.4060B
Joint-Type B-4545	45	45	37.5	1xFD+1xFX	665	8.31.4545B
Joint-Type B-4560	45	60	37.5	1xFD+1xFX	815	8.31.4560B
Joint-Type C-4040	40	40	35	1xFD+1xFX	575	8.31.4040C
Joint-Type C-4060	40	60	35	1xFD+1xFX	695	8.31.4060C
Joint-Type C-4545	45	45	37.5	1xFD+1xFX	665	8.31.4545C
Joint-Type C-4560	45	60	37.5	1xFD+1xFX	815	8.31.4560C

Note: offer per set (including fastening set).