

Panel Installation Elements

Panel Mounting Block

To attach panel to strut profile, choosing block attach face can get two different indent for various panel thickness.

Material and Color: Block-black PC Nut insert-stainless steel

Panel Mounting Block-6

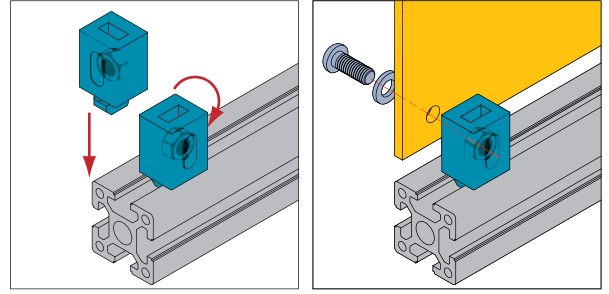
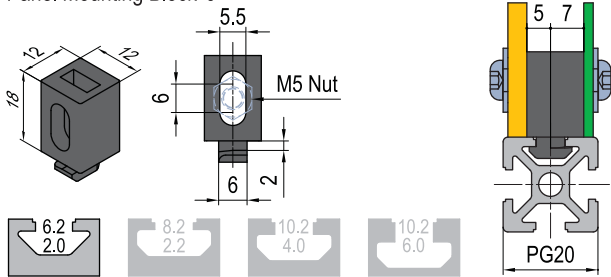

Panel Mounting Block-8

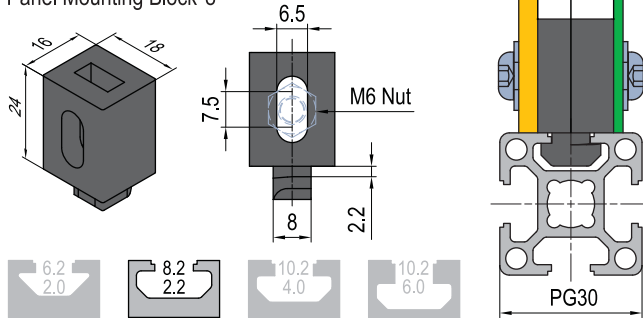



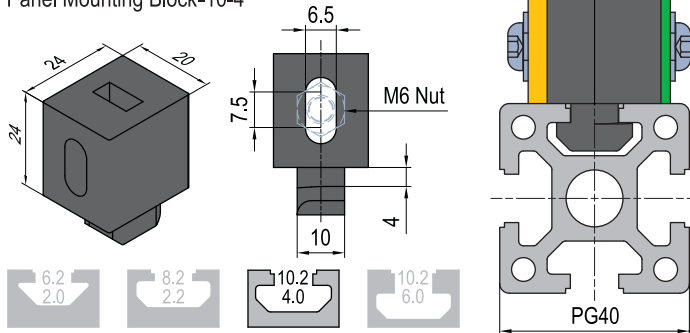

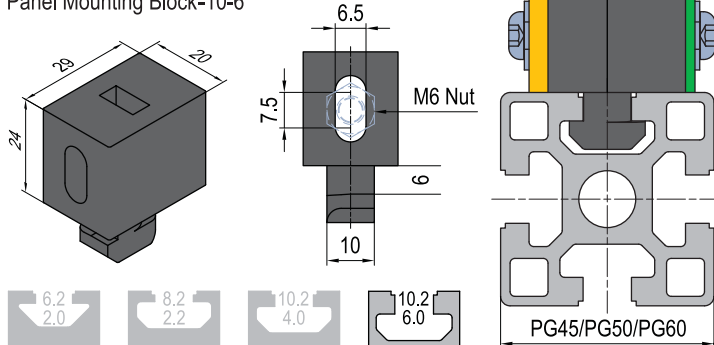

Panel Mounting Block-10-4



Panel Mounting Block-10-6



FM	Fastening Set	FN	Fastening Set	FP	Fastening Set
	M5x14 Bolt zinc plated		M6x16 Bolt zinc plated		M6x25 Bolt zinc plated
	M5 Washer zinc plated		M6 Washer zinc plated		M6 Washer zinc plated

Description	Fastening Set	Mass (g)	Part No.
Panel Mounting Block-6 (pcs)		4.4	6.21.06
Panel Mounting Block-6 (set)	1xFM	7	6.21.06.ST
Panel Mounting Block-8 (pcs)		9	6.21.08
Panel Mounting Block-8 (set)	1xFN	13.5	6.21.08.ST
Panel Mounting Block-10-4 (pcs)		15.8	6.21.10.04
Panel Mounting Block-10-4 (set)	1xFP	23.8	6.21.10.04.ST
Panel Mounting Block-10-6 (pcs)		20	6.21.10.06
Panel Mounting Block-10-6 (set)	1xFP	29	6.21.10.06.ST